

The PROENS relay announcement combinations realize the indication and routing progresses of the all defects and failures that will probably occur on the protection cells in electric networks. It is a micro-controller based device.

There are 24 PCS of announcement Inputs and 3 pcs of announcement Outputs on the device. By way of these Inputs, it becomes able to process and route the defect announcement information.

Announcement relay(*option) can work in full accord with Modbus RTU communication output and scada system.

With the internal buzzer property, the announcement relay can provide sound alarm without the need of external sound alarm hardware.

The transmission of HORN, BELL and INTERNAL FAULT announcements are provided through the output relays.

Relay input configuration can be done by buttons on front panel.

The LEDS that are placed on the device are double colored as GREEN and RED.

The speed of signal processing and signal transmission is lower than 16msec. Thus, the excessive circuit in the high and medium voltage use doesn't interfere in the relay coordination.

Inputs are optically isolated.

Working Principle:

Leds:

1.Led Modes:

*Steady: After the input signal is acknowledged , signal is not exist more.

*Quick Flash : The announcement signal is recognized but it is not confirmed.

*Slow Flash: After the input signal is acknowledged , signal is continuous.

Led Colors:

·Red: Horn ·Green: Bell



BELL-HORN LED: It is Red on Horn Output.It is Green on Bell output. It flashes as red-green on bell and horn output is activated.

FAIL-SAFE LED: It is green on relay is energized and working is normal.It is red on relay is energized and working is not normal.

2.:OUTPUTS

·HORN Relay: It pulls the ignition when an announce-ment input signal.

·Bell Relay: It pulls the ignition when an announcement input signal.

·Fail Safe Relay: When relay is energised it changes position.If relay doesn't change the position its mean is internal fault on relay. By the control of the relay can understand of relay is working or not.This system controls by micro-controller.

3.BUTTONS:

·ACK Button: It provides the recognized announcement information to be confirmed by the operator.

·DEL Button: It switches off the stable continuous leds.

·STOP Button: It releases the Buzzer, Horn and silences the buzzer.

·Lamb Test Button: It is used to check the conditions of the leds.The green and red leds flashes in sequence when it is pushed.It shows the input configuration when holds 3 second duration.

TECHNICAL PROPERTIES

Operating Voltage	24 VDC,48 VDC,110 VDC, 220VDC,110 VAC,220 VAC	Color of Indicator Buttons	Red,Green
Voltage Variation	(0,8-1,2)*Un	Alarm Ack Button	20.000 Presses
Announcement Voltage Input	24VDC,48VDC,110VDC	Lamp Test Button	YES
Announcement Input	Optically Isolated	Del Button	YES
Announcement Input Current	2mA	Stop Button	YES
Contact Currents	2A -24VDC,110VDC-0.4A,220VDC-0.2A	Fail Safe Led	YES
Number of Announcements	24	Horn Bell Led	YES
Number Relay Outputs	3	Assembly	To front of the panel
Internal Sound Alarm	Buzzer * 80db @5cm	Cable Section	2,5 mm max.
Filtering Time	5.5 msec	Operating Temperature	.-20 + 55 °C
Transmission Time	10 msec	Protection Class	IP 20
Communication (*CM)	Modbus RTU-19200 Baud	Weight	*
Communication Isolation (*CM)	2.5 KV	Dimensions	550x230x120 mm
Indicator	Led 100.000 hour		

WORKING DIAGRAM

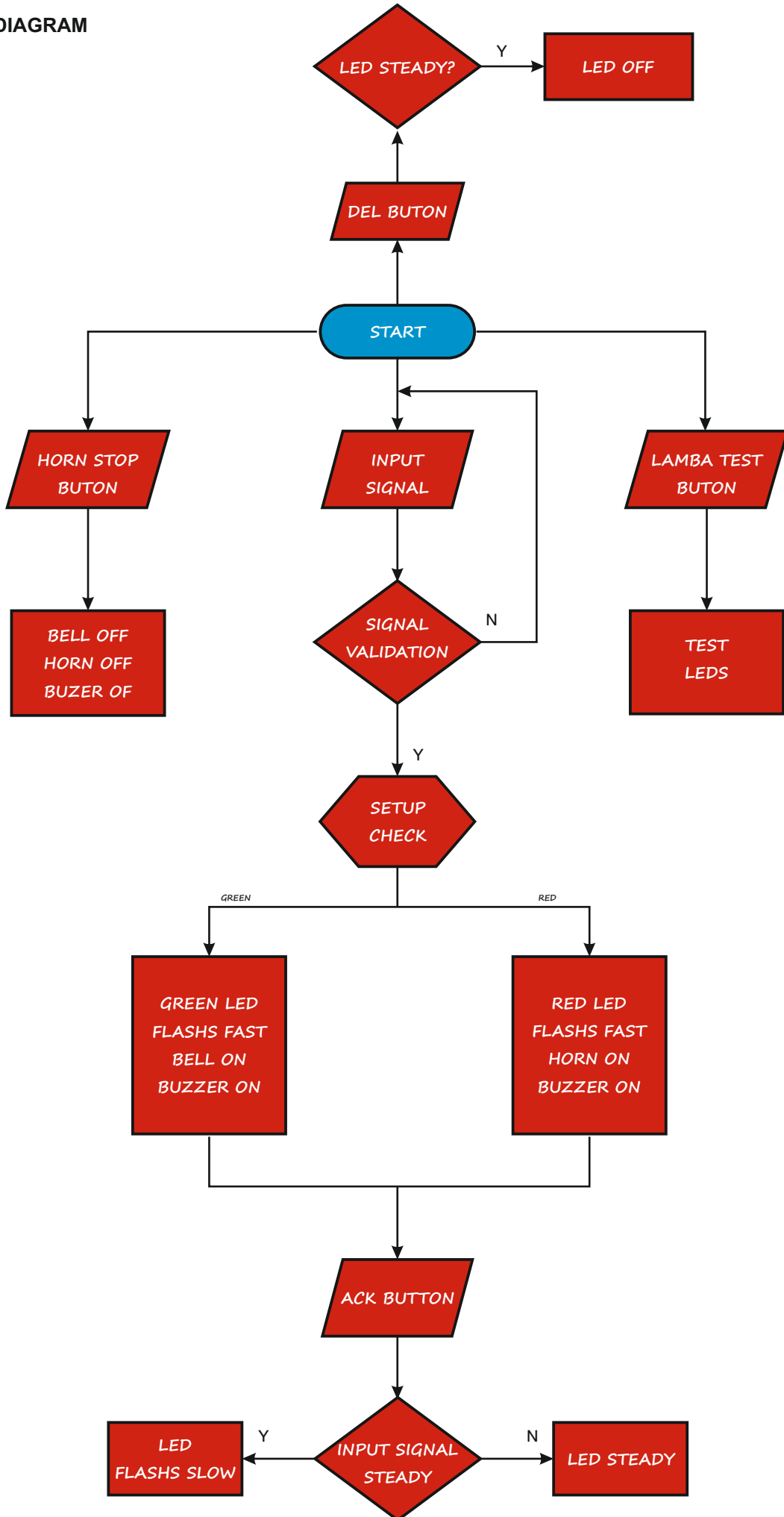

ORDERING TABLE

ORDER CODE	DESCRIPTION
ASB-124DB-CA-24VDC	Without Communication 24VDC Supply
ASB-124DB-CA-48VDC	Without Communication 48VDC Supply
ASB-124DB-CA-110VDC	Without Communication 110VDC Supply
ASB-124DB-CA-220VDC	Without Communication 220VDC Supply
*ASB-124DB-CA-110VAC	Without Communication 110VAC Supply
*ASB-124DB-CA-220VAC	Without Communication 220VAC Supply
ASB-124DB-CM-24VDC	With Communication 24VDC Supply
ASB-124DB-CM-48VDC	With Communication 48VDC Supply
ASB-124DB-CM-110VDC	With Communication 110VDC Supply
ASB-124DB-CM-220VDC	With Communication 220VDC Supply
*ASB-124DB-CM-110VAC	With Communication 110VAC Supply
*ASB-124DB-CM-220VAC	With Communication 220VAC Supply

* Input voltage must be chosen as 24VDC,48VDC,110VDC.
 * Ask for special supply voltages that you need.

DIMENSIONS

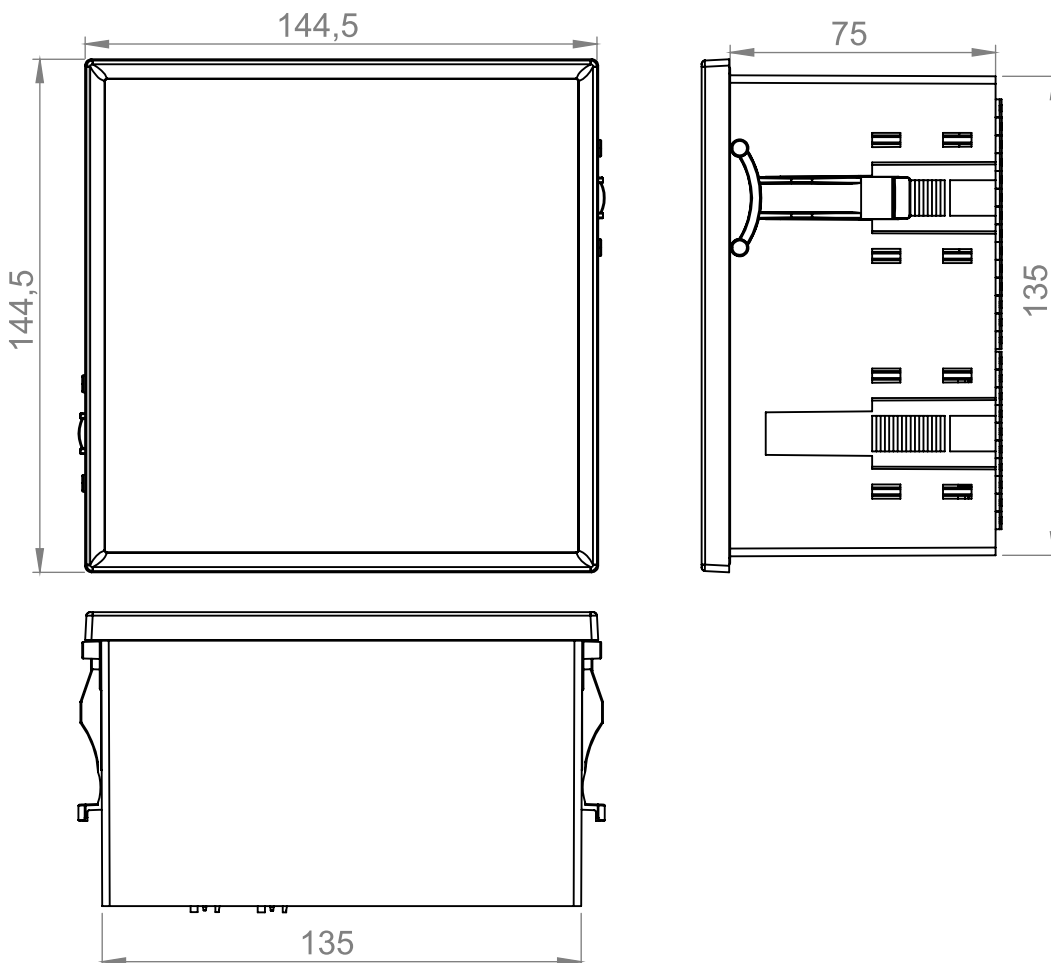

Signal Labels Mounting:

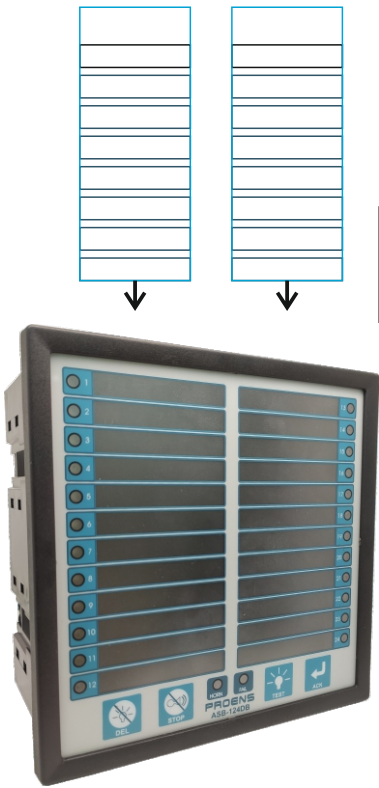

Remove the outer frame gently separating it from the tabs of the box.

After Cutting A4 printout template that you printed. Place the papers you have cut into label pockets. Close the frame gently.

*****You can contact to us for label templates.**